

CONDENSERS

Condensers are used for condensation of vapours and cooling of liquids. Condensers are by fusing number of parallel coils in a glass shell. Coils are made in different made diameters using tubes of different bores.

The average co-efficient of heat transfer in coil condenser is considered as-

Condensation 200 - 270 Kcal/m²,hr,°C approx.
Cooling 100 - 150 Kcal/m²,hr,°C approx.

Cat. Ref.	DN	d/ DN1	L	L1	Type	Actual H.T.A. m ²	Cross Area Cm ²	Free Coolant Rate Kg/hr.	Max. Jacket Cap. Litre
HE3/3.5*	80	16	600	75	A	0.35	5	1300	2
HE4/5*	100	19	600	75	A	0.50	30	2400	4
HE4/6*	100	19	750	100	A	0.60	30	2400	6
HE6/10	150	25	600	100	B	1.00	52	2600	9
HE6/15*	150	25	850	100	B	1.50	52	2600	11
HE9/25*	225	25	800	110	B	2.50	125	3300	18
HE12/25	300	25	600	125	B	2.50	175	5700	25
HE12/40*	300	25	900	125	B	4.00	175	5700	35
HE16/40	400	25	600	125	B	4.00	450	6200	60
HE16/50	400	25	700	125	B	5.00	450	6200	70
HE18/60	450	40	750	150	C	6.00	820	4800	100
HE18/80	450	40	900	150	C	8.00	820	6200	110
HE24/120	600	50	1250	300	C	12.00	1520	6200	265

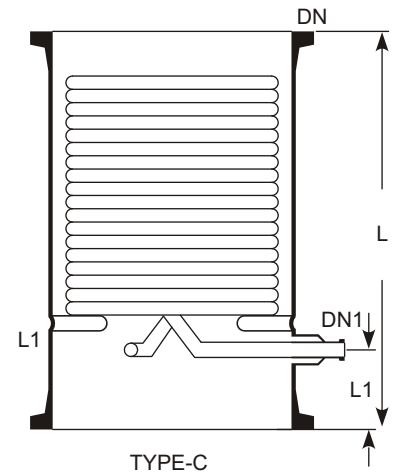
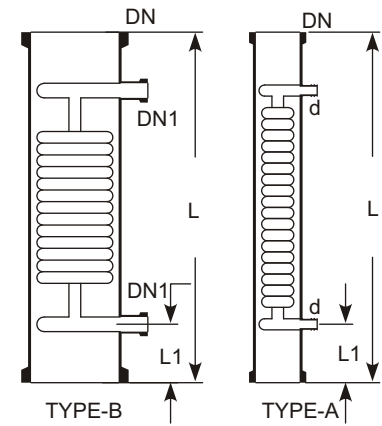

Precautions to be taken in use of condensers

- Vapours should be passed through shell only.
- Maximum pressure of coolant should be 2.7 bars.
- Adequate flow of coolant should be used.
- Steam should not be used in coils.
- Coolant should not be heated to boiling point.
- Coolant control valve should be turned slowly.
- Coolant should be allowed to drain freely.
- Brine can be used in coils in a closed circuit.
- Water main should be connected with flexible hose.
- Ensure no freezing of water remaining in the coils.
- Condensers should be mounted vertically only.
- Condensers can be mounted in series to provide larger surface area.

METHODS OF USE

Vapours from bottom

This method is simple to install over a reactor. However this results in condensate returning substantially at its condensing temperature. In this method care must be taken that condensate is not excessive that it can lead to "logging" the coils and create back pressure in the system. Generally a reflux divider is used below the condenser to take out the distillate.

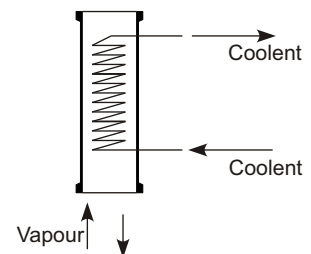

Vapours from top

This method produce a cool condensate using the entire cooling surface area. This method should be used where the condensate can lead to "logging" of coils.

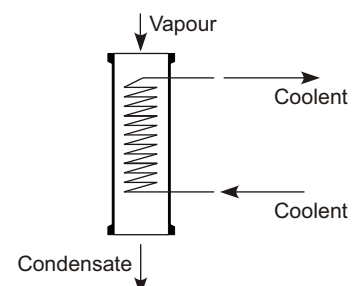

BOLIERS

Boilers are used for vaporization of liquids by passing the steam in the coils. Boilers are made by fusing number of parallel coils in a glass shell. In Boilers, coils are designed to provide bigger cross section in the shell side as compared to condensers.

The average heat transfer in Boilers is considered as 350 Kcal/m²,hr,°C at a steam pressure of 3.5 bar.

Cat. Ref.	DN	DN1	DN2	L	L1	Type	Actual H.T.A. m ²	Free Cross Area Cm ²	Jacket Cap. Litre
HEB4	100	25	25	375	100	A	0.15	40	2
HEB4/4	100	100	25	400	100	B	0.15	40	3
HEB6	150	40	25	450	100	A	0.35	50	5
HEB6/6	150	150	25	500	100	B	0.35	50	7
HEB9	225	40	25	700	100	A	1.00	150	16
HEB9/9	225	225	25	700	100	B	1.00	180	20
HEB12/12	300	300	25	700	125	B	1.30	330	40

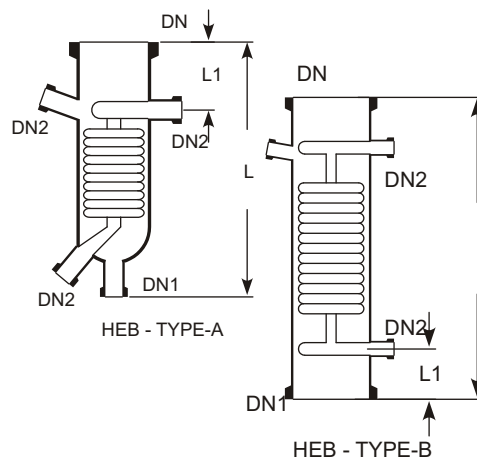

Notes on use of Boilers :

- Steam should be passed in the coils at a maximum pressure of 3.5 bar which is equivalent to a temperature of 147 °C.
- For higher temperature (maximum upto 200 °C) heat transfer fluids can be passed in the coils. - Coldliquids
- Cold liquids should be preheated for better results.
- Boilers should be mounted in an external circulatory loop (as shown in figure) and not direct at the bottom of flask or column
- Under certain circumstances, boilers can be mounted in series to provide larger heat transfer area.

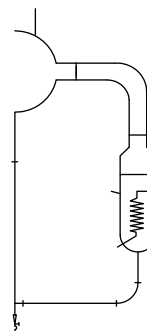

ANGLED HOSE CONNECTOR ASSEMBLIES

Metal / Plastic angled hose connector assemblies are available to connect the flexible hose to the condensers. These are provided with a mating flange, a rubber gasket and nut bolts.

Cat.Ref.	DN	d	L
PMC1	25	22	70

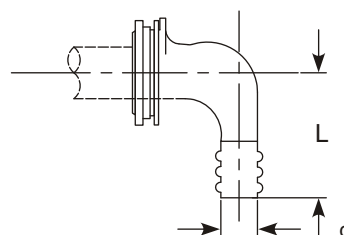

IMMERSIONS

Immersion heat exchangers are used to control exothermic reaction in glass vessels. They can be used with vessels having wider bottom outlet (type VSR and VSE). These are provided with a central hole through the coil battery so that a special, extended type, stirrer can be fitted which extends to the bottom of heat exchanger and provide through action.

In most applications, cooling water is used in coils (max. pressure 2.7 bar g.), but they can also be used with steam (max. pressure 3.5 bar g.). In latter case the coils must be completely immersed in liquid. Immersions are not recommended for use with products which have a tendency to crystallise.

Cat. Ref.	DN	DN1	DN2	L	L1	L2	d	Actual H.T.A. m ²
HEM6	150	40	25	200	200	75	145	0.4
HEM9	225	40	25	300	200	75	200	0.6

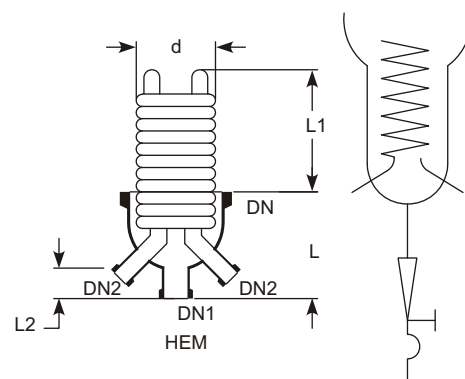

PRODUCT COOLERS

Product coolers are used for cooling of liquids, typically, for the cooling of distillates from the distillation columns.

Unlike coil condensers, in product coolers, product travels through the coil battery and coolant through shell. This provides more resident time to the product to be cooled. For direct connection with distillate lines, all the product coolers are provided with 25 DN connections.

Cat.Ref.	DN	DN1	DN2	L	Actual HTA m ²	Type
HEF1/1*	50	25	12	450	0.1	A
HEF1/2*	50	25	12	600	0.2	A
HEF1/3.5*	80	25	16	600	0.35	A
HEF1/5*	100	25	19	600	0.5	A
HEF1/10	150	25	25	600	0.7	B
HEF1/15	150	25	25	850	1.25	B

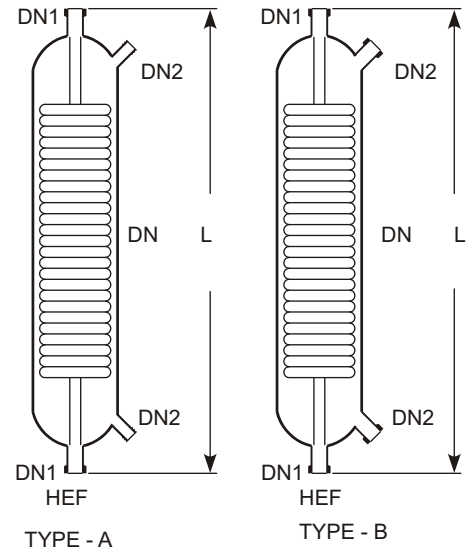

UTILITY CONNECTION FOR CONDENSER

When installing coil type heat exchangers appropriate precautions should be taken. The main points to be taken into account when planning to use these items as coolers are (See also flow chart below).

