

# HEAT EXCHANGERS



The overall heat transfer co-efficient of Borosilicate glass equipment is comparatively favourable with many alternative materials because of its smooth surface which improves the thermal coefficient & reduce the tendency of fouling.

Heat Exchangers are available in 2 basics designs:

1. Conventional Coil Type Condensers.
2. Shell & Tube Type.

## SHELL AND TUBE HEAT EXCHANGERS

### INTRODUCTION

Shell & tube heat exchangers offer large surface area in combination with efficient heat transfer and compactness. These are widely used in industries for various duties like cooling, heating, condensation, evaporation etc. Global are the pioneers in the field of glass shell and tube heat exchangers in India and their product has a wide market acceptability.

### SALIENT FEATURES

1. Universal corrosion resistance an excellent alternative to expensive MOCs like graphite, hastelloy, copper titanium, tantalum and other exotic metals.
2. Excellent heat transfer as fouling does not occur on smooth glass surfaces.
3. Flexibility of installation vertical / horizontal.
4. Easy replacement of tubes for repair and cleaning.
5. Available in wide range of HTAs.
6. Ease of installation due to light weight.
7. Economical.
8. Suitable for applications where large HTAs are required in limited space.

### ADVANTAGES OVER CONVENTIONAL COIL TYPE HEAT EXCHANGERS

- (1) The overall heat transfer coefficient in shell and tube heat exchanger is about 3 times higher than in coil type heat exchanger.
- (2) The pressure drop in shell and tube heat exchanger is minimal compared to 2-3 kg/cm<sup>2</sup> in coil side of coil type heat exchanger.
- (3) For requirement of higher heat transfer areas shell and tube heat exchanger is the only alternative.

### CONSTRUCTION FEATURES

The glass tubes are sealed individually into PTFE tube sheet with special PTFE sockets and packing. This unique ferrule type sealing arrangement permits easy replacement and cleaning of tubes. Baffles on shell side ensure improved heat transfer by increased turbulence. Further details of construction can be seen in the diagram.

- Made from SCHOTT DURAN.
- Joint less tubes offer better pressure rating.

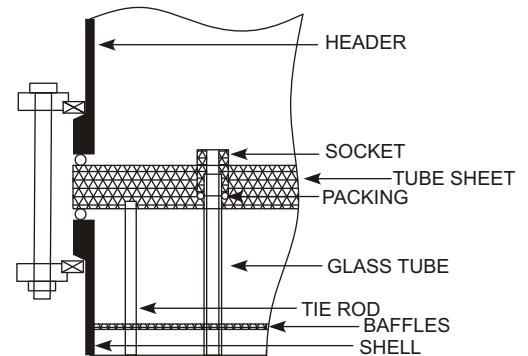

### TYPE

Three basic versions \* are available :

Model	Material Of Construction			Duty
	Shell	Tube	Header	
RGG	Glass	Glass	Glass	For heat transfer between two aggressive media.
RGM	Glass	Glass	Steel/ FRP	For heat transfer between aggressive media in shell & non-aggressive media in tubes.
RMG	Steel/FRP	Glass	Glass	For heat transfer between aggressive media in tubes & non-aggressive media in shell.

## DIMENSIONAL SPECIFICATIONS

Cat. Ref. RGG/RMG	6/3	6/4	6/5	6/6	9/6	9/8	9/10	9/12	12/12	12/16	12/21	12/25
Area (m <sup>2</sup> )	3	4	5	6	6	8	10	12	12	16	21	25
DN	150				225				300			
DN1	80				100				150			
DN2	50				80				80			
DN3	25				40				40			
DN4	50				50				50			
H1	175				250				300			
H2	150				200				250			
L	2500	3100	3700	4300	2620	3220	3820	4520	2550	3150	3950	4550
L1	1900	2500	3100	3700	1900	2500	3100	3800	1800	2400	3200	3800
L2	150	150	150	150	225	225	225	225	225	225	225	225
L3	1600	2200	2800	3400	1450	2050	2650	3350	1350	1950	2750	3350
L4	250	250	250	250	300	300	300	300	300	300	300	300
L5	125	125	125	125	175	175	175	175	175	175	175	175
L6	1980	2580	3180	3780	2000	2600	3200	3900	1930	2530	3330	3930
T	50				60				75			
No. of Tubes	37				73				151			
No. of Baffles	11	15	19	23	7	9	13	17	5	7	9	11

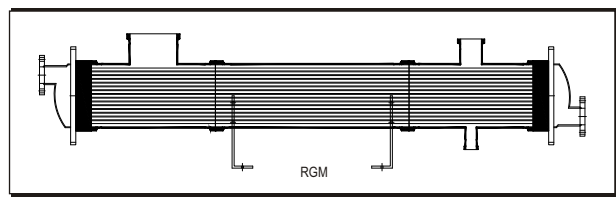
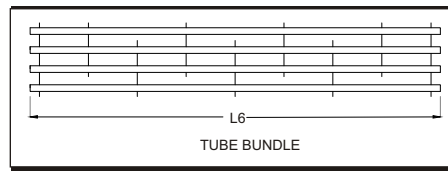
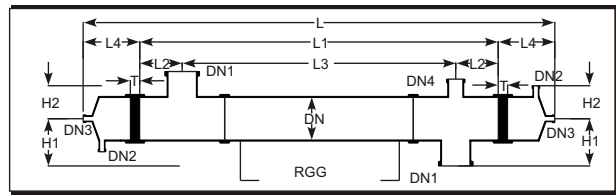

## RANGE OF APPLICATIONS

Permissible temperature range for both shell & tube sides - 40°C to 150°C.  
 Maximum permissible temperature difference between shell & tube sides 120°C.  
 All sizes & models are suitable for full vacuum on both side. Maximum limiting pressures are tabulated here below :

Model	Side	Maximum Permissible Pressure Range, Kg/cm <sup>2</sup> (g)		
		150 DN	225 DN	300 DN
RGG	Shell	2.0	1.0	1.0
	Tube	2.0	1.0	1.0
RGM	Shell	2.0	1.0	1.0
	Tube	3.5	3.5	3.5
RMG	Shell	3.5	3.5	3.5
	Tube	2.0	1.0	1.0



The above ranges of application are admissible limiting values. For each specific case GLOBAL recommends the admissible operating data based on the relations between pressure and temperature, size and model.

## PERFORMANCE & DESIGN DATA

The particular advantage of shell & tube heat exchanger is high heat transfer performance. The relation between heat transfer and velocity of flow can be easily seen in the diagram. On receipt of the operating data from client the most favourable shell and tube heat exchanger is selected. This accurate design combined with most reliable quality assurance ensure economy and operational reliability for the user. For approximate sizing some typical heat transfer coefficients are given here below :

Media	use	U-Values	
		kcal/m <sup>2</sup> hr k	W/m <sup>2</sup> k 300
Steam water	Condensation	350-550	410-640
Water-Water	Cooling	250-350	290-410
Water-air	Cooling	30-60	35-70

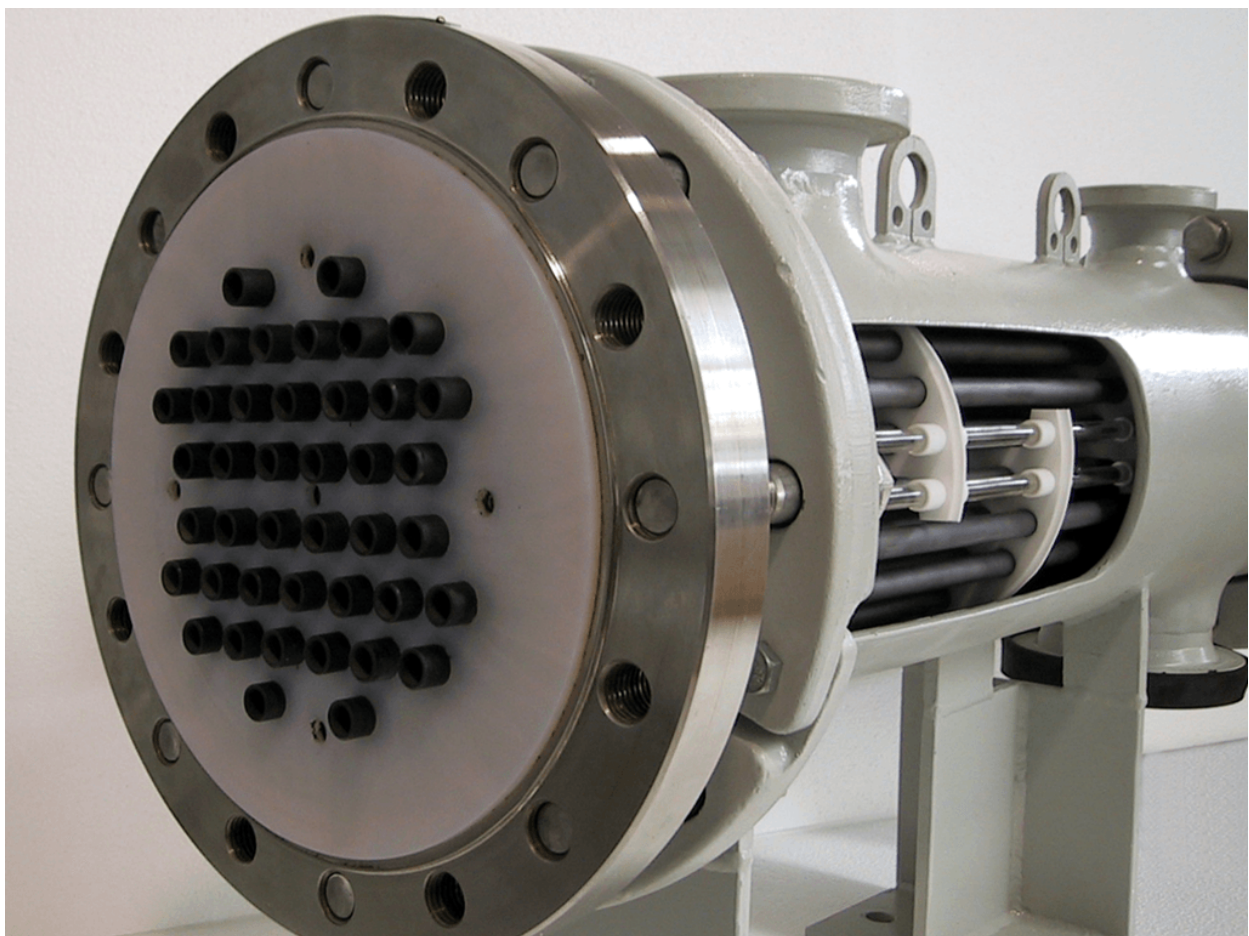
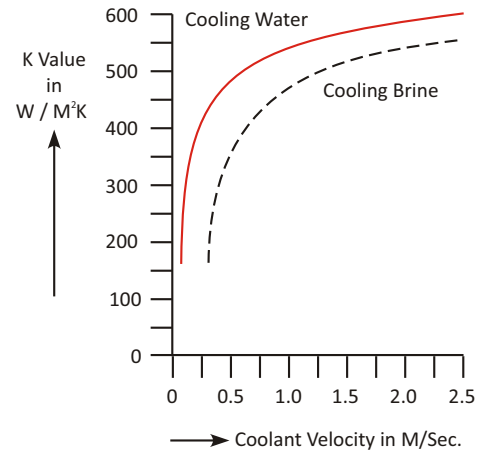

**GRAPHITE TUBE HEAT EXCHANGER**

## CONDENSERS

Condensers are used for condensation of vapours and cooling of liquids. Condensers are by fusing number of parallel coils in a glass shell. Coils are made in different made diameters using tubes of different bores.

The average co-efficient of heat transfer in coil condenser is considered as-

Condensation 200 - 270 Kcal/m<sup>2</sup>,hr,°C approx.  
Cooling 100 - 150 Kcal/m<sup>2</sup>,hr,°C approx.

Cat. Ref.	DN	d/ DN1	L	L1	Type	Actual H.T.A. m <sup>2</sup>	Cross Area Cm <sup>2</sup>	Free Coolant Rate Kg/hr.	Max. Jacket Cap. Litre
HE3/3.5*	80	16	600	75	A	0.35	5	1300	2
HE4/5*	100	19	600	75	A	0.50	30	2400	4
HE4/6*	100	19	750	100	A	0.60	30	2400	6
HE6/10	150	25	600	100	B	1.00	52	2600	9
HE6/15*	150	25	850	100	B	1.50	52	2600	11
HE9/25*	225	25	800	110	B	2.50	125	3300	18
HE12/25	300	25	600	125	B	2.50	175	5700	25
HE12/40*	300	25	900	125	B	4.00	175	5700	35
HE16/40	400	25	600	125	B	4.00	450	6200	60
HE16/50	400	25	700	125	B	5.00	450	6200	70
HE18/60	450	40	750	150	C	6.00	820	4800	100
HE18/80	450	40	900	150	C	8.00	820	6200	110
HE24/120	600	50	1250	300	C	12.00	1520	6200	265

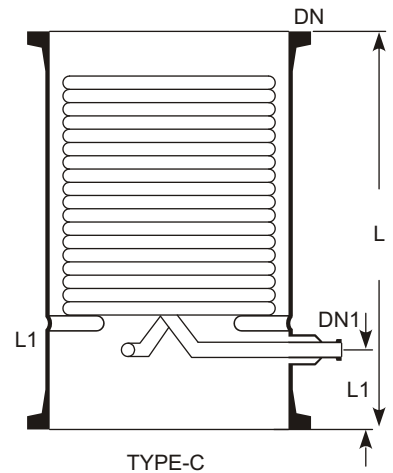
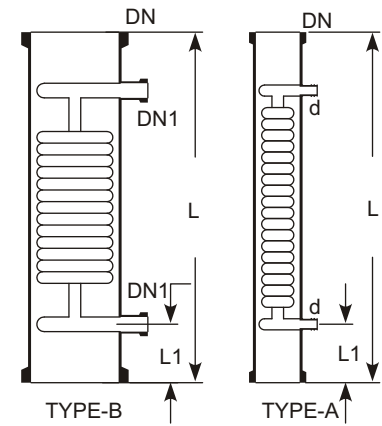

### Precautions to be taken in use of condensers

- Vapours should be passed through shell only.
- Maximum pressure of coolant should be 2.7 bars.
- Adequate flow of coolant should be used.
- Steam should not be used in coils.
- Coolant should not be heated to boiling point.
- Coolant control valve should be turned slowly.
- Coolant should be allowed to drain freely.
- Brine can be used in coils in a closed circuit.
- Water main should be connected with flexible hose.
- Ensure no freezing of water remaining in the coils.
- Condensers should be mounted vertically only.
- Condensers can be mounted in series to provide larger surface area.

## METHODS OF USE

### Vapours from bottom

This method is simple to install over a reactor. However this results in condensate returning substantially at its condensing temperature. In this method care must be taken that condensate is not excessive that it can lead to "logging" the coils and create back pressure in the system. Generally a reflux divider is used below the condenser to take out the distillate.

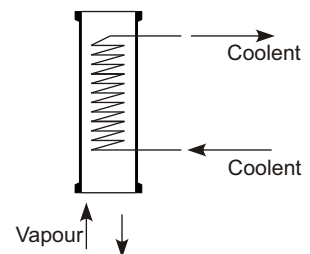

### Vapours from top

This method produce a cool condensate using the entire cooling surface area. This method should be used where the condensate can lead to "logging" of coils.

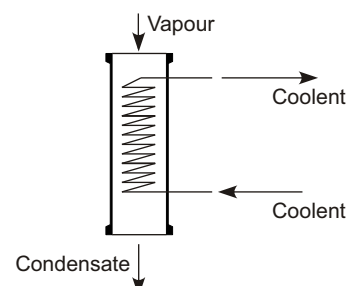

## BOLIERS

Boilers are used for vaporization of liquids by passing the steam in the coils. Boilers are made by fusing number of parallel coils in a glass shell. In Boilers, coils are designed to provide bigger cross section in the shell side as compared to condensers.

The average heat transfer in Boilers is considered as 350 Kcal/m<sup>2</sup>,hr,°C at a steam pressure of 3.5 bar.

Cat. Ref.	DN	DN1	DN2	L	L1	Type	Actual H.T.A. m <sup>2</sup>	Free Cross Area Cm <sup>2</sup>	Jacket Cap. Litre
HEB4	100	25	25	375	100	A	0.15	40	2
HEB4/4	100	100	25	400	100	B	0.15	40	3
HEB6	150	40	25	450	100	A	0.35	50	5
HEB6/6	150	150	25	500	100	B	0.35	50	7
HEB9	225	40	25	700	100	A	1.00	150	16
HEB9/9	225	225	25	700	100	B	1.00	180	20
HEB12/12	300	300	25	700	125	B	1.30	330	40

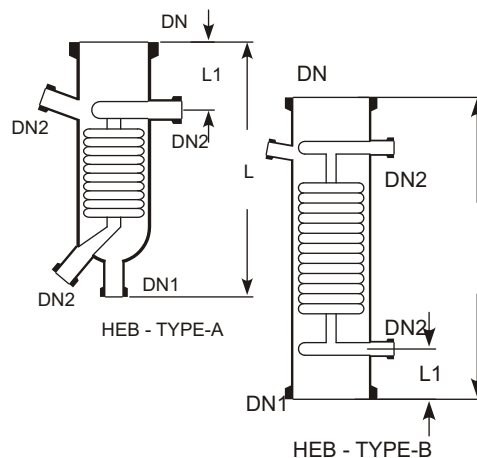

### Notes on use of Boilers :

- Steam should be passed in the coils at a maximum pressure of 3.5 bar which is equivalent to a temperature of 147 °C.
- For higher temperature (maximum upto 200 °C) heat transfer fluids can be passed in the coils. - Coldliquids
- Cold liquids should be preheated for better results.
- Boilers should be mounted in an external circulatory loop (as shown in figure) and not direct at the bottom of flask or column
- Under certain circumstances, boilers can be mounted in series to provide larger heat transfer area.

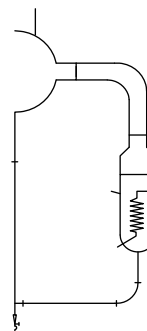

## ANGLED HOSE CONNECTOR ASSEMBLIES

Metal / Plastic angled hose connector assemblies are available to connect the flexible hose to the condensers. These are provided with a mating flange, a rubber gasket and nut bolts.

Cat.Ref.	DN	d	L
PMC1	25	22	70

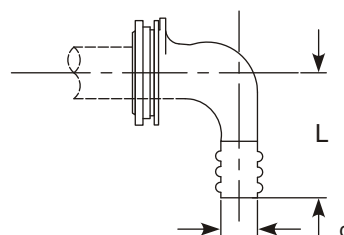

## IMMERSIONS

Immersion heat exchangers are used to control exothermic reaction in glass vessels. They can be used with vessels having wider bottom outlet (type VSR and VSE). These are provided with a central hole through the coil battery so that a special, extended type, stirrer can be fitted which extends to the bottom of heat exchanger and provide through action.

In most applications, cooling water is used in coils (max. pressure 2.7 bar g.), but they can also be used with steam (max. pressure 3.5 bar g.). In latter case the coils must be completely immersed in liquid. Immersions are not recommended for use with products which have a tendency to crystallise.

Cat. Ref.	DN	DN1	DN2	L	L1	L2	d	Actual H.T.A. m <sup>2</sup>
HEM6	150	40	25	200	200	75	145	0.4
HEM9	225	40	25	300	200	75	200	0.6

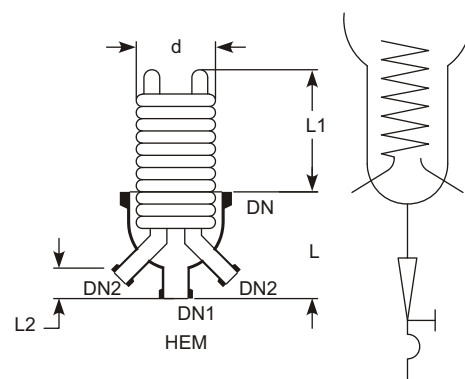

## PRODUCT COOLERS

Product coolers are used for cooling of liquids, typically, for the cooling of distillates from the distillation columns.

Unlike coil condensers, in product coolers, product travels through the coil battery and coolant through shell. This provides more resident time to the product to be cooled. For direct connection with distillate lines, all the product coolers are provided with 25 DN connections.

Cat.Ref.	DN	DN1	DN2	L	Actual HTA m <sup>2</sup>	Type
HEF1/1*	50	25	12	450	0.1	A
HEF1/2*	50	25	12	600	0.2	A
HEF1/3.5*	80	25	16	600	0.35	A
HEF1/5*	100	25	19	600	0.5	A
HEF1/10	150	25	25	600	0.7	B
HEF1/15	150	25	25	850	1.25	B

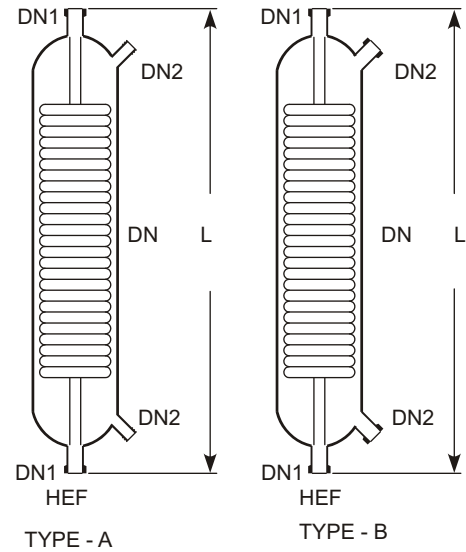

## UTILITY CONNECTION FOR CONDENSER

When installing coil type heat exchangers appropriate precautions should be taken. The main points to be taken into account when planning to use these items as coolers are (See also flow chart below).

